

Technical information

on the fully automatic carton packer

Specification:

- Highly modern control of the machine via touch screen
- Carton folder
- Introduction of bottles using multiple insertion arms
- Sealing of cartons with adhesive tape
- Printing of an arbitrary text on the cartons (e.g. "06/09" or "09 desert"), an EAN code or a running number

Important:

- Form, dimensions and material of the lables, capsules and packaging material must be checked by us in advance.
- The machine can only process cartons that have been delivered correctly folded. Cartons with seperators can be folded by hand in an emergency, but incorrectly folded cartons with separators cannot be processed.

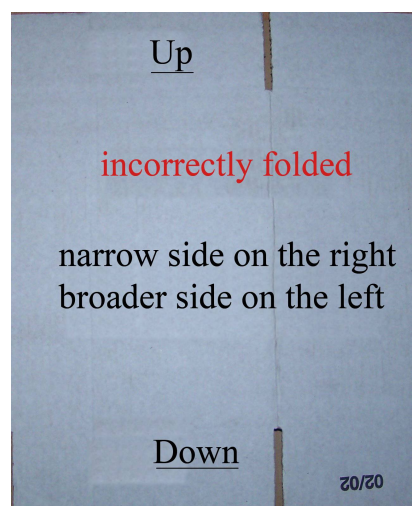
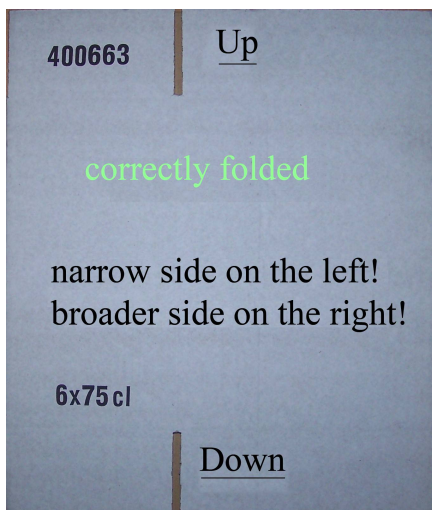

The machine also can be used in isolation!

Technical Data:

- Throughput up to 3000 bottles per hour
- Power requirements: 5 kW (32A CEE plug with 20 Amp. fuse)
- Bottle sizes: from 0,5 L (70mm) to 1,0 L (91mm) Other sizes by arrangement
- Bottle height: 185 to 400 mm
- Cartons for 6 or 12 bottles with or without separators can be processed.

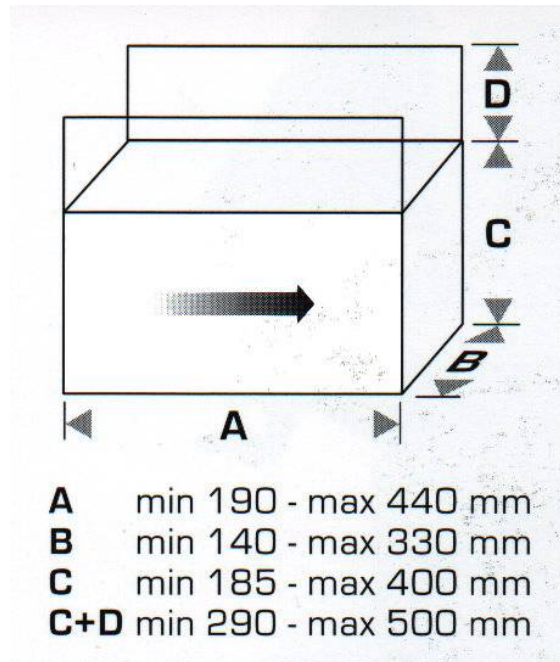

Dimensions of the machine / trailer

- length: 4.91 meters (ready to roll) 6.31 meters (operational). The total length in operational state together with the labelling machine is: 10.36 meters.
- Width: 2.32 meters (ready to roll) 2.94 meters (operational)
- Height: about 2.55 meters.